

## Safety Information



**IMPORTANT:** THIS PRODUCT MUST BE INSTALLED IN ACCORDANCE WITH THE APPLICABLE NATIONAL ELECTRICAL CODE AND LOCAL BUILDING CODES BY A PERSON FAMILIAR WITH THE CONSTRUCTION AND OPERATION OF THE PRODUCT AND THE HAZARDS INVOLVED.

### SAVE THESE INSTRUCTIONS.



**WARNING:** Before installation or servicing, turn the power OFF at the circuit breaker or fuse. Place tape over the circuit breaker switch and verify power is OFF at the light fixture.



**WARNING:** Ground the fixture to avoid potential electric shock.



**WARNING:** Wear gloves when handling the fixture as edges are sharp.



**CAUTION:** Connect the fixture to a 120-277 Volt, 60 Hz power source. Any other connection voids the warranty.

**NOTICE:** FCC Regulations state that any unauthorized changes or modifications to this equipment not expressly approved by the manufacturer could void the user's authorization to operate this equipment.



**IMPORTANT:** The device is tested and found to comply with Part 15 of the FCC Rules. Operation is subject to two conditions: (1) This device may not cause harmful interference and, (2) this device must accept any interference received, including any interference that may cause undesired operation.

This equipment has been tested and found to comply with the limits for a Class A digital device, pursuant to Part 15 of the FCC rules. These limits are designed to provide reasonable protection against harmful interference when the equipment is operated in a commercial environment.

The equipment generates, uses, and can radiate radio frequency energy and, if not installed and used in accordance with the instruction manual, may cause harmful interference to radio communications. However, there is no guarantee that interference will not occur in a particular installation. If this equipment does cause harmful interference to radio or television reception, which can be determined by turning the equipment off and on, the user is encouraged to try to correct the interference by one or more of the following measures:

- Reorient or relocate the receiving antenna.
- Increase the separation between the equipment and receiver.
- Connect the equipment into an outlet on a circuit different from that to which the receiver is connected.
- Consult the dealer or an experienced radio/TV technician for help.

# INSTALLATION STANDARD RECESSED MOUNT



**WARNING:** Before you begin, turn the power off at the circuit breaker or fuse box to avoid electric shock.

## 1 Remove the ceiling panel

- Remove the grid tile from the ceiling.

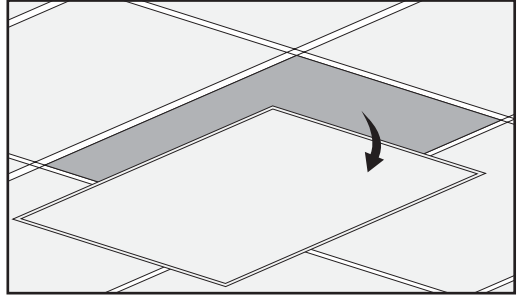

## 2 Connect the wires

- Lift the fixture to the ceiling.
- Follow the steps in the **Make the Electrical Connections** section of this manual.

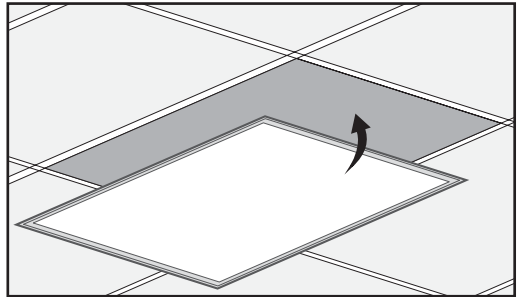

## 3 Select CCT and Wattage

- 5CCT adjustment

Wattage adjustment dependent upon fixture size, choices (pre-set to highest wattage).

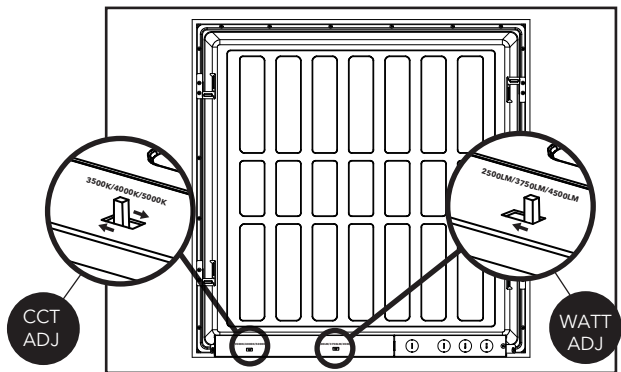

## 4 Complete the installation

- Slide the fixture into the ceiling grid.
- Attach earthquake clips by bending over the grid rails.
- Restore power to the fixture.

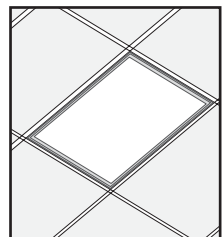
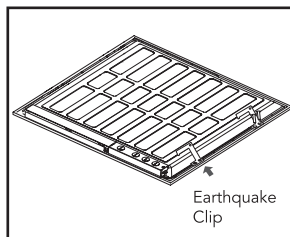

# MAKING THE ELECTRICAL CONNECTIONS



**WARNING:** Before you begin, turn the power off at the circuit breaker or fuse box to avoid electric shock.

## 1 Open the junction box

- a. Unscrew and remove the junction box cover (1) from the fixture.

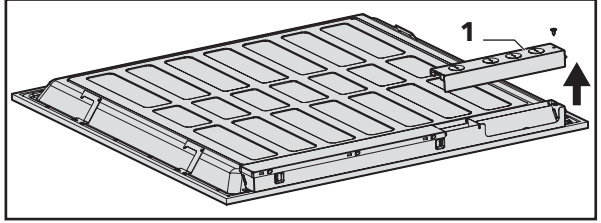

## 2 Connect the supply wires

- a. Connect the green ground wire from the fixture to the supply ground wire.
- b. Connect the white wire from the fixture to the supply white wire (neutral wire).
- c. Connect the black wire from the fixture to the supply black wire (live wire).
- d. Secure the three connections using three of the supplied wire nuts (AA).
- e. Wrap the three wire connections with electrical tape for a more secure connection (electrical tape not included).

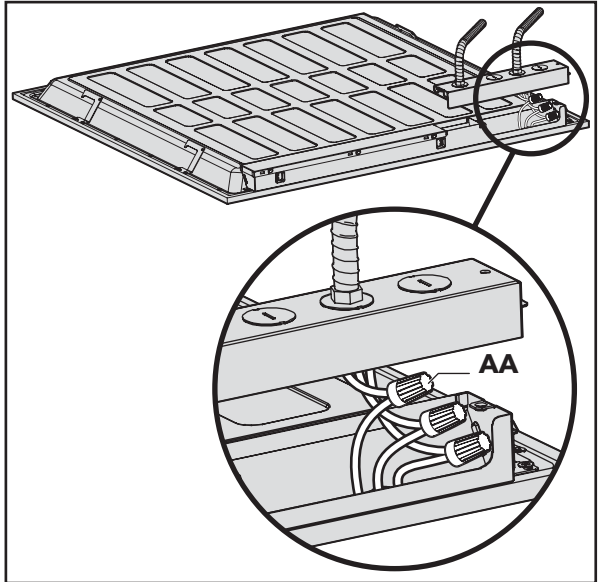

## MAKING THE ELECTRICAL CONNECTIONS (CONTINUED)

### 3 Connect the dimming wires

- Connect the purple wire from the fixture to the purple (DIM+) supply wire.
- Connect pink wire from fixture to pink (DIM-) supply wire.  
**\*\*NOTE:** If supply wire has not been updated per new NEMA requirement, DIM- wire maybe gray.
- Secure the two connections using the remaining two supplied wire nuts (AA).
- Wrap the two wire connections with electrical tape for a more secure connection (electrical tape not included).

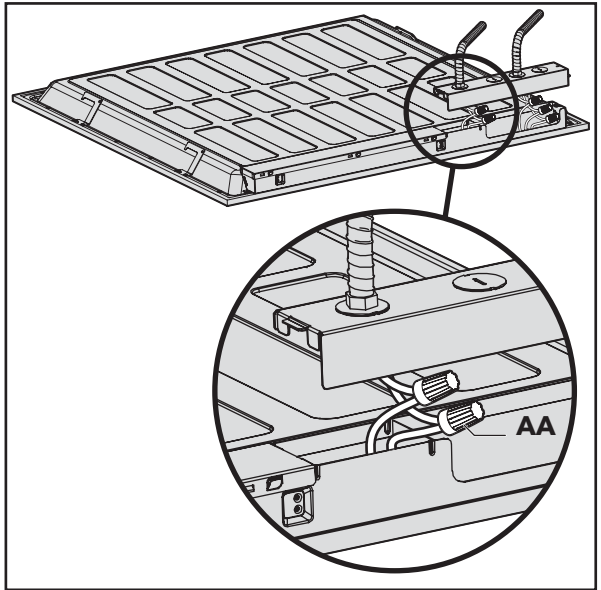

### 4 Reinstall the junction box cover

- Position the wires back inside the junction box.
- Reinstall the junction box cover (1). Secure with screw.

